

Insert compatible with the game:
**GREAT WESTERN TRAIL:
 NEW ZEALAND**

Please remove elements out of frame carefully.
 It is recommended to use a blade at the cutline
 to punch element out of the sheet easier.

Assemble based on element letter,
 then from lowest to highest number.

Layout inside the gamebox:

①

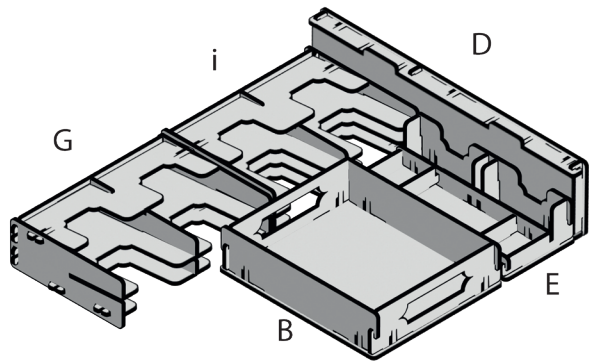

②

