

Please remove elements out of frame carefully.

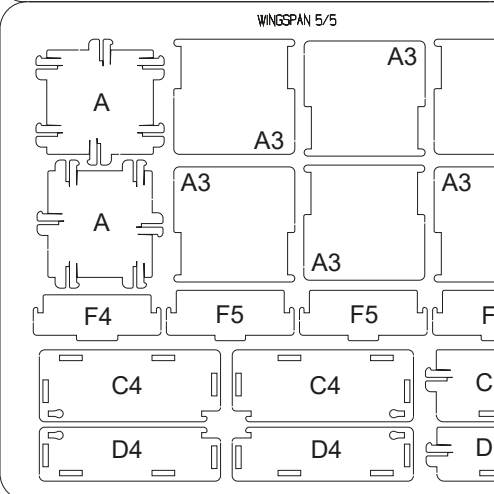
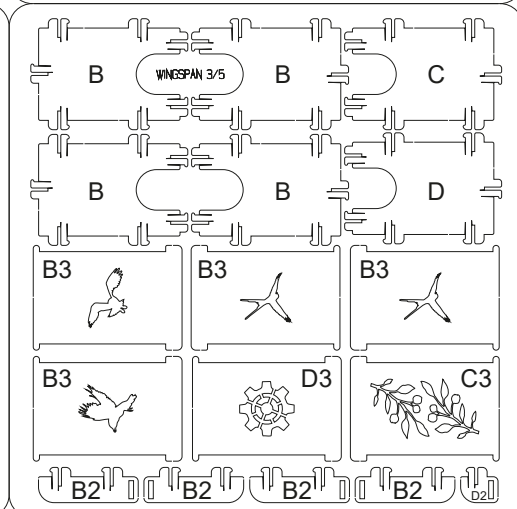
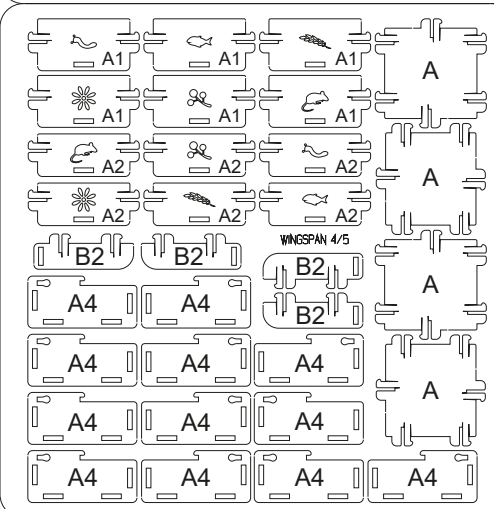
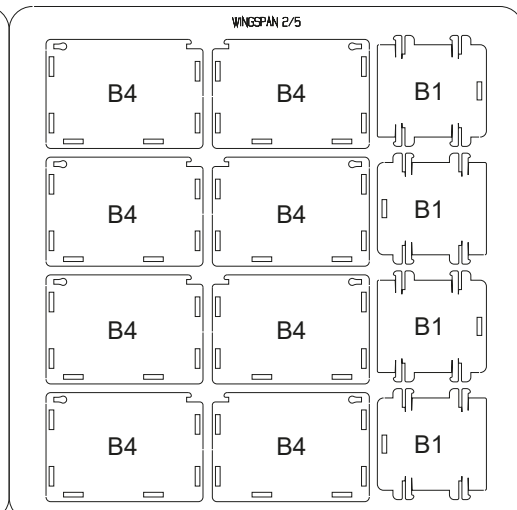
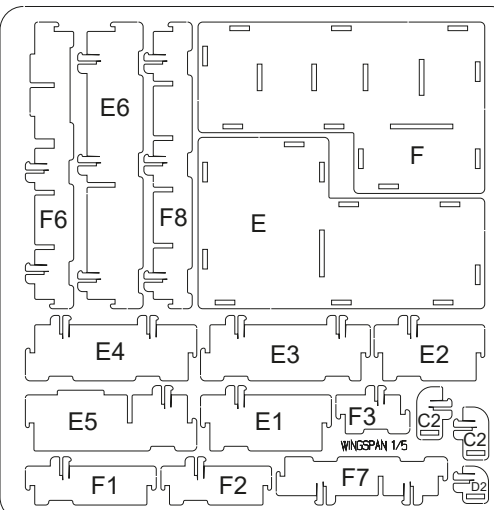

Assemble based on base element letter then according to numbers from first to last.

Example: while assembling **A** start by inserting all elements **A1** into base element **A**, then all elements **A2** and so on.

Compatible with the game: **WINGSPAN**

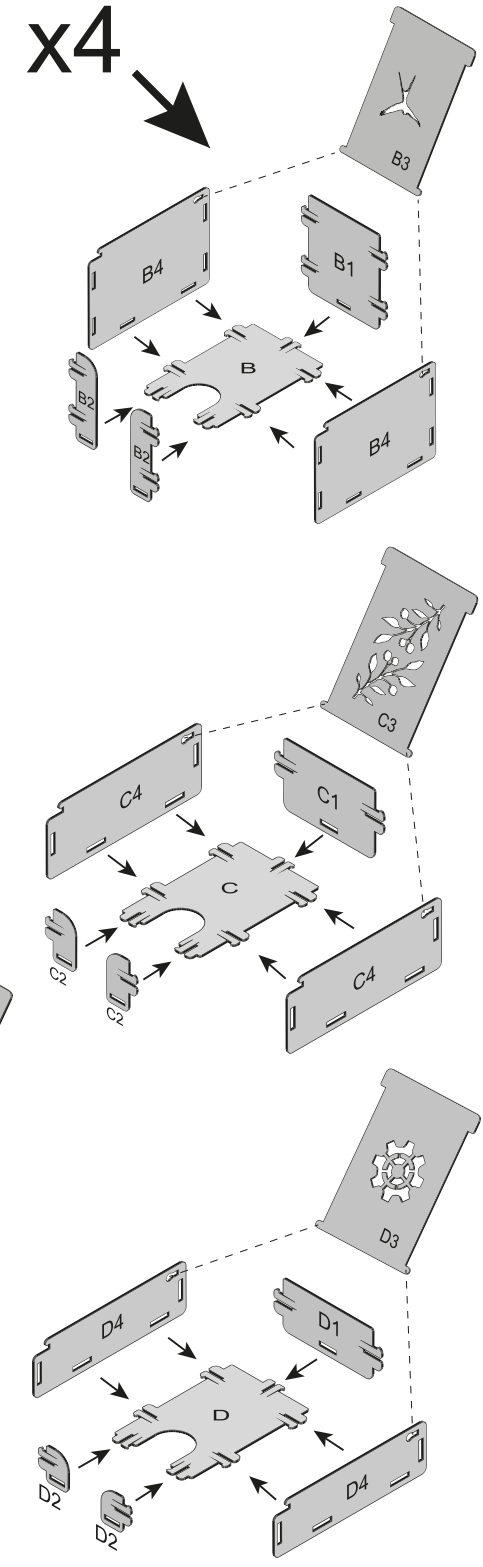
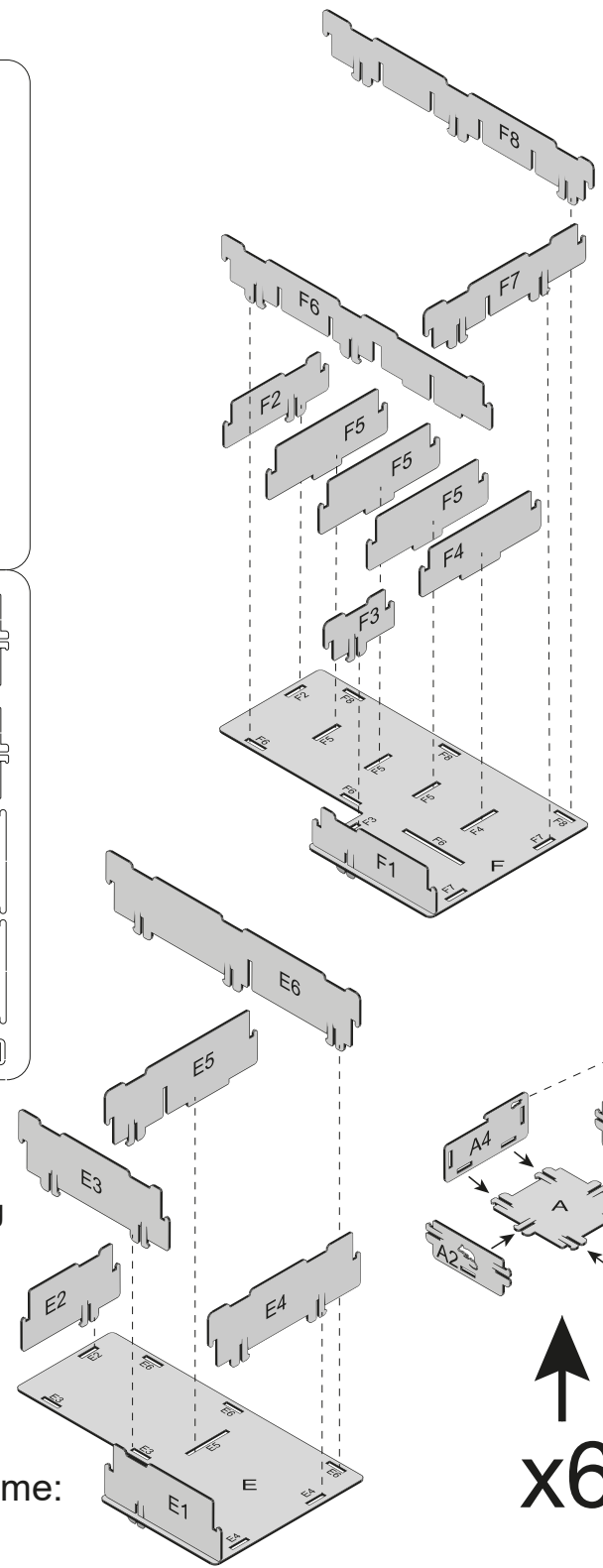

x6

x4

DICE TOWER COMPATIBLE WITH

WINGSPAN

GAME

1

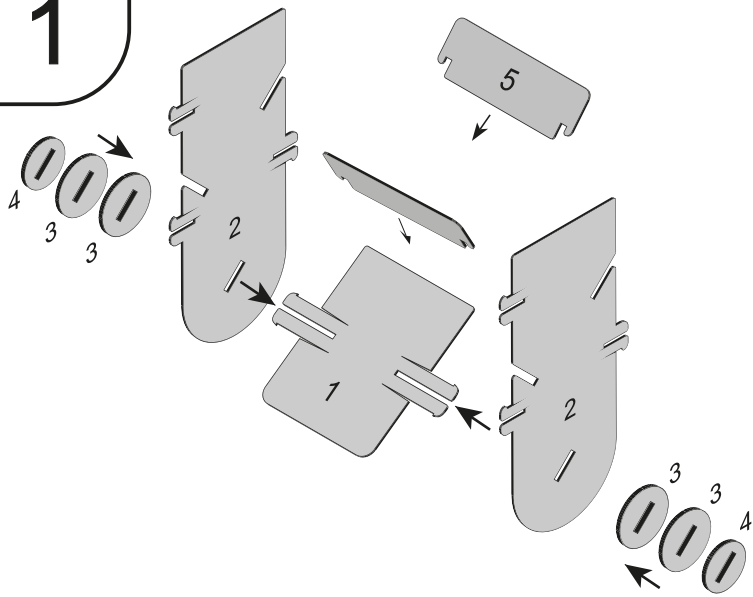

2

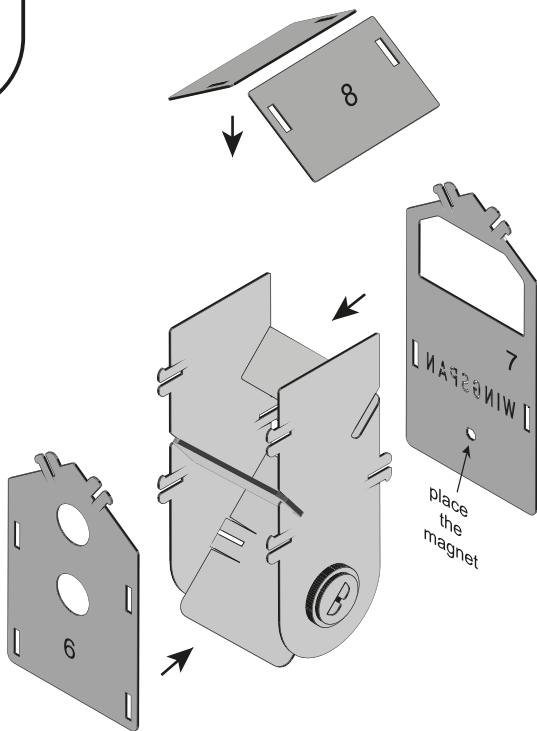

3

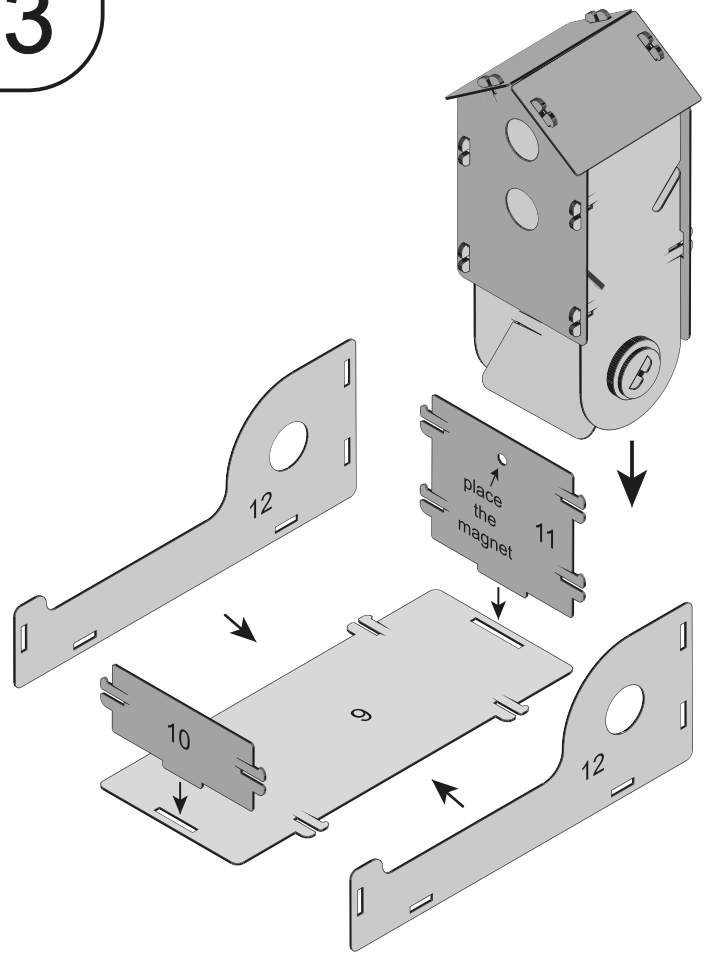

4

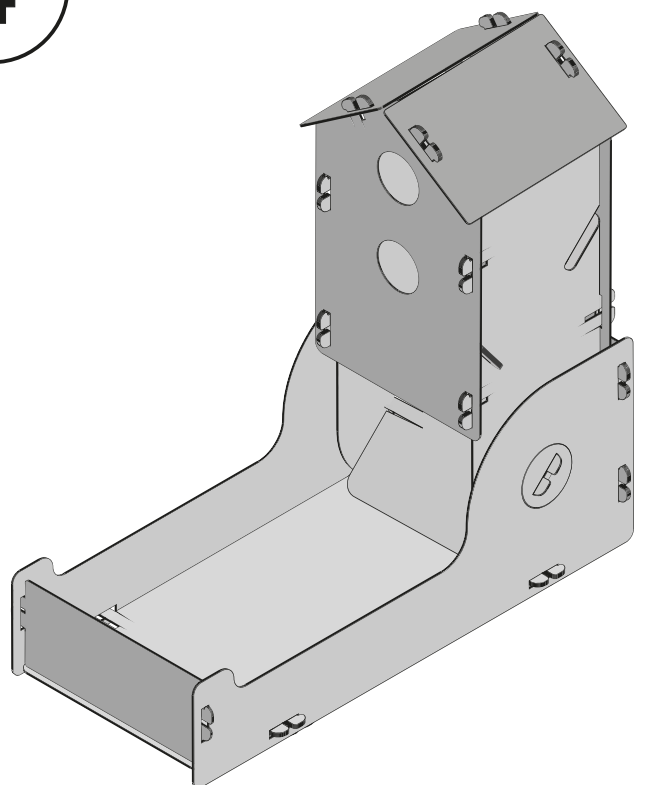

Please remove elements out of frame carefully.

